

Redi2Weld

Fully Automated Pipe
Welding System



TABLE OF CONTENTS

01 Introduction

03 What We Offer

06 Redi2Weld

07 Features

09 Main Components

15 Layout Options

23 Contact Us



WELCOME TO REDI2WELD

The Redi2Weld line of automated pipe welding systems has been developed to give fabricators the ability to choose the right kind of automation for their specific application. Weld automation can increase deposition rates by keeping the arc on longer with high welding consistency.

Redi2Weld offers adaptability because each shop is different and fabricators should have flexibility when looking at equipment and not be forced into only one type of layout or weld process.



Manufactured in Texas

Redi2Weld is designed and manufactured by Industrial Solutions & Innovation in Houston, Texas. ISI has been a leader in providing quality solutions to their clients for two decades.

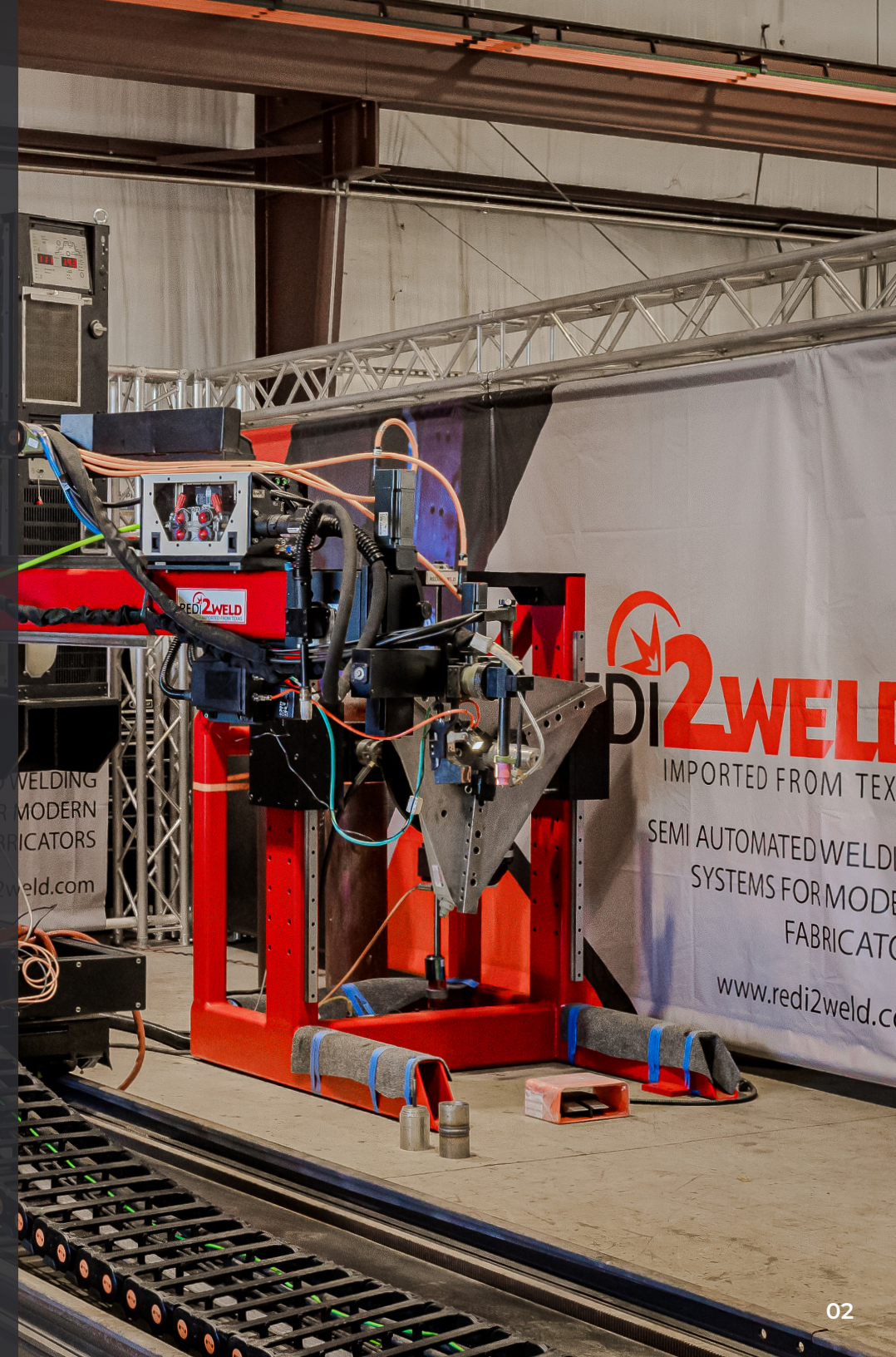



AUTOMATED WELDING EQUIPMENT FOR THE **MODERN** FABRICATOR

Why Choose Redi2Weld?

Designed by Welders, for Welders.



FLEXIBILITY IN DESIGN

Allows you to select a layout that will work for you in your shop.



MORE FEATURES

More features for a lower cost gives you a quicker ROI.



SIMPLE PROGRAMMING

Straightforward programming allows welders to gain confidence quickly and reduce implementation time.



IN HOUSE ENGINEERING

Engineering and development capabilities to help you develop WPS and PQR documentation for implementation.

RENTAL OPTIONS

We understand that committing to a piece of machinery can be daunting. That's why we offer rentals options so you can try it before you buy it.

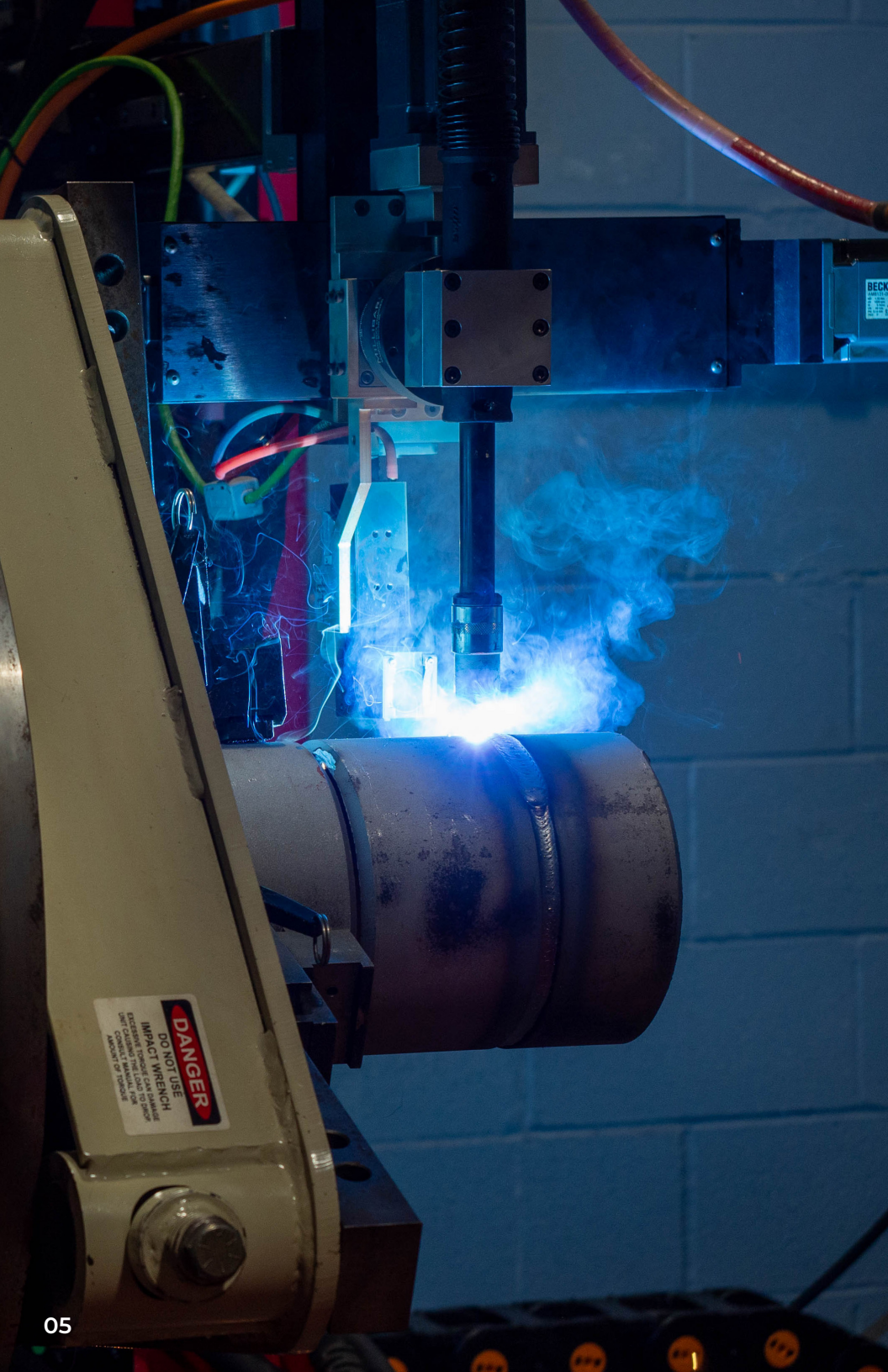

Redi2Weld

The Redi2Weld system gives you the flexibility to use TIG and MIG on the same automated welding platform. It can be configured with parallel headstocks and a column and boom that can articulate 180 degrees so that while you're welding in one bay, the opposite bay can be loading up your next spool. When finished, the working spool can be off-loaded and the operator can simply rotate the column and boom 180 degrees to the pre-loaded bay in order to keep the arc time at a really high level of efficiency.

Our systems also give you the added benefit of being able to add-on functionality at a later date. You can expand the number of headstocks and system length, along with adding MIG or TIG capability at a later date. The machine can truly grow with you.

All of our Redi2Weld Systems are manufactured in Texas, which means you have stateside installation, training, and support.



Scan the
QR code
to see our
Redi2Weld
in action

Redi2Weld Standard Features & Options



Features:	Redi2Weld
MIG/FCAW Capabilities (including Metal Core)	Yes
Saw Welding	In Development
TIG Welding	Yes
Hot Wire TIG Welding	Yes
Drum Wire Feed Capabilities	Optional
Multiple Amperage options on Power Supplies	Yes
Multiple Wire Feeders	Optional
Tandem Wire MIG Capabilities	Optional
Socket Welding Capabilities	Yes
Vision System	Yes
Pendular Oscillation	Yes
Horizontal and Vertical Axis for Fine Tune Steering	Yes
Automated ARC Height Control	Yes
Real Time Data Acquisition Functionality	Yes
Capable of Integrating to Fabrication Monitoring/ Tracking Software Systems	In Development
Multiple Layout Options	Yes
Customizable Layout	Yes
Number of Variations for System Layout	8
Capable of Welding 45' Spools	Yes
Manual Torch for Repair or Out of Tolerance Fit Up	Optional



Main Components

WELDING CART

Redi2Weld is designed with productivity in mind. The automated welding cart travels on hardened machine rails with a robust rack and pinion and high-precision guide rollers with smart encoded drive motors for pipe and vessel welding. The cart also holds the Column and Boom with optional rotation capacity, power supplies (MIG – TIG or BOTH), and optional drum feed. The boom features the ability to tilt the torch to allow for welding of socket welds and slip on flanges. All of this comes with efficient and discrete cable management and single source power to afford a safer and cleaner work environment.

HEADSTOCKS

The Redi2Weld headstocks and rotation solutions are designed in house and are manufactured by Redi2Weld.

We use extremely high precision slew ring bearings to both accurately rotate pipe spools at a precise speed and to prevent any backlash or vibration in the rotation when encountering moments of inertia. Headstocks come with mechanized vertical travel to afford the adjustment of centerline of the pipe spool and to afford the swing of longer tangent branch connections. Headstocks come with a 3 jaw gripper with hardened teeth to ensure a safe and secure operation. Gripper sizes are set according to your needs.

Main Components, Cont.

PLC

An intuitive controller allows you to program in every aspect of the weld. This allows you to weld root to cap without stopping to change programs or settings. Programs are stored for later use and varying levels of override can be set for security purposes.

CAVITAR WELDING CAMERA

Allows the operator to be removed from the arc, enabling them to remotely monitor the process through a water-cooled camera without the need for a welding helmet. The camera removes all of the arc flash, giving operators a clear view of each pass and reducing the risk of operator fatigue throughout multiple welding passes. Altogether, the automated system and the Cavitar Weld Camera help create welds at a high rate of efficiency and quality.

Alternative Camera Options: Xiris Camera System

REMOTE PENDANT

Designed with operator safety in mind, the remote pendant allows the operator to get away from the arc and complete the weld without a hood by using the remote along with the Cavitar Welding Camera.

POWER SUPPLIES

Redi2Weld systems utilize EWM Automation Series Power supplies. In each Redi2Weld system you have the option of configuring the system for MIG/FCAW only OR TIG/Hot Wire TIG only. Alternately, you can choose to configure your system with both MIG and TIG functionality:

Standard MIG systems include the EWM Phoenix 552 power supply and water cooler for MIG/MAG modes including: MIG, FCAW and Metal Core. The Phoenix 552 provides up to 550 amps of current while allow you to weld with RootArc (modified short circuit for rooting), ForceArc (highly advanced spray mode) or ForceArc Puls (highly advanced spray mode with pulse technology).

Standard TIG systems include the EWM Tetrax 352 power supply with Hot Wire capability and the TIGSPEED Robo Feed wire feed system that provides wire oscillation as well as hot wire current. The Tetrax 352 provides 350 amps of current, 180 amps of hot wire current, and wire oscillation of up to 16Hz.

Redi2Weld also gives you the flexibility to add either MIG or TIG functionality at a later date to afford you greater control over your budget and implementation cost.

ADDITIONAL OPTIONS

- Additional wire feeders for both MIG and TIG systems
- Drum wire feed (250 & 500 lb capacity)
- Manual torch on board to allow for repairs to welds or manual welding of joints that cannot be fit "correctly"
- EWM XNet weld Data Recording
- Additional pipe supports
- Vessel welding with "growing line" using integrated turning rolls
- Linear or long seam welding functionality

Layout Options

Single Headstock | Dual Head Stock
Vessel Welding with Headstock

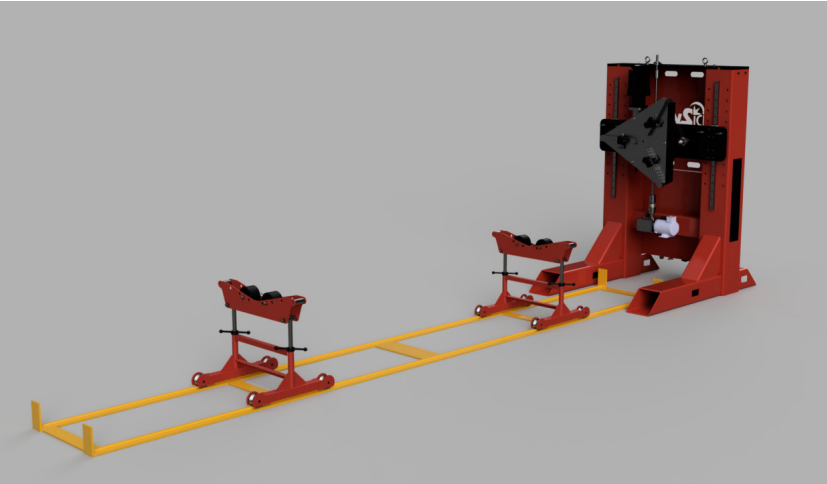
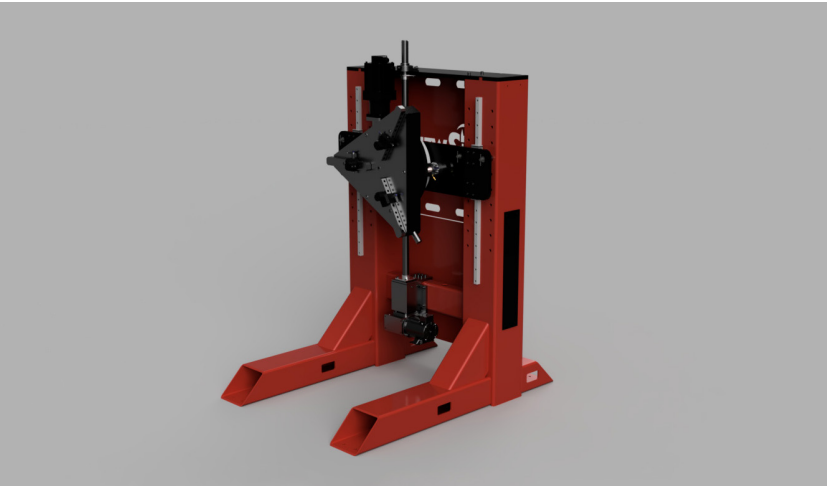
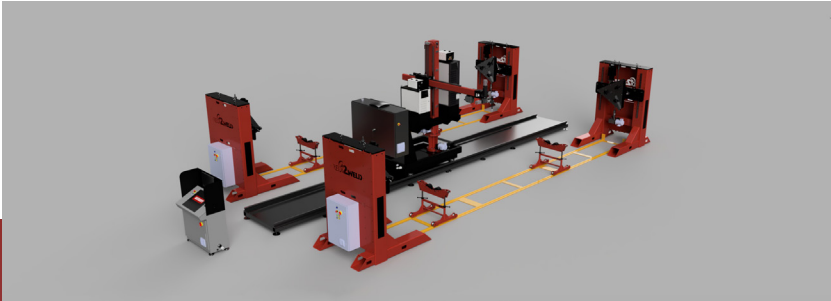
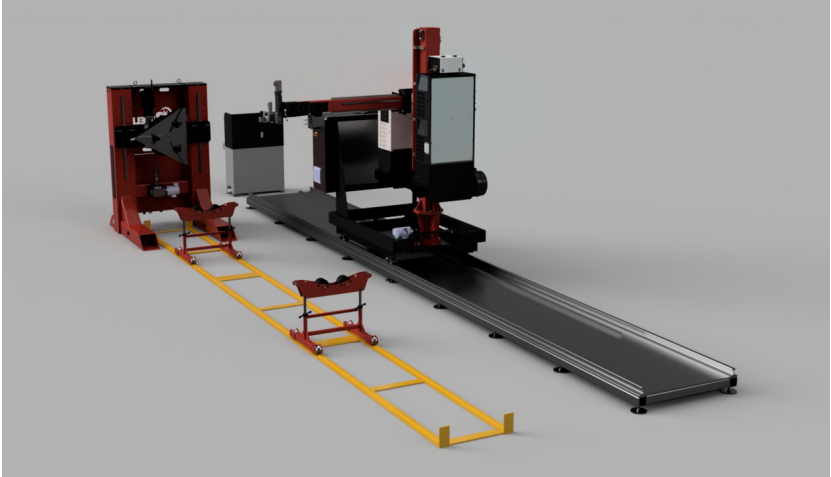

Contact Us

Phone 281-824-0356
Email info@redi2weld.com
Address 4420 Mustang Rd, Alvin, TX 77511
Web www.redi2weld.com

www.redi2weld.com